

Symbol

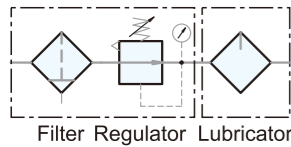

Features

1. Remove water and particle effectively.
2. 40 μ m and 5 μ m filter element are easily interchangeable and replaceable.
3. Accurate and easy pressure setting.
4. Lubricator oil can be replenished without stopping air supply.
5. Oil spray in mist ensures good lubrication for machines.
6. Anti-acid & alkali bowl and aluminum bowl provide excellent protection in organic chemistry working environments.
(Please contact our sales for more inquiries.)



*Lubricator oil (Recommended): ISO-VG32

How to order

NUFR/L - 02	N	C	G	H	A	SB	
F.R.L combination	Port size	Thread	Filtration	Gauge type	Drain	Bowl	Spacer block
Filter Regulator +Lubricator	02 : 1/4" 03 : 3/8" 04 : 1/2"	Blank :G N :NPT R :Rc	PE Blank :5 μ m C :40 μ m Sintered brass S :5 μ m T :40 μ m	Blank :Square G :Circle	Blank :Semi-auto drain H :Manual drain D :Auto drain	Blank :Standard bowl A :Anti-acid & alkali bowl AL :Aluminum bowl	Blank :W/O Spacer block SB :Spacer block (Port size 1/8")

Please contact our sales for non-relieving type.

*For non-relieving type, the secondary pressure is not allowed to be exhausted when it is higher than setting pressure.

Specifications

Model	NUFR/L-02	NUFR/L-03	NUFR/L-04
Port size	1/4"	3/8"	1/2"
Fluid	Compressed air		
Regulator construction	Piston		
Body material	Aluminum die-cast		
Bowl material	Polycarbonate (Standard), Anti-acid & alkali bowl (Option), Aluminum bowl (Option)		
Filtration	PE: 5 μ m (Standard), 40 μ m (Option); Sintered brass(Option):5 μ m, 40 μ m		
Operating pressure range	0.5 ~ 9.9 kgf/cm ²		
Max. inlet pressure	15 kgf/cm ²		
Max. flow rate l/min (ANR)	2080	2100	2600
Ambient temperature	-10 $^{\circ}$ C ~ 60 $^{\circ}$ C		
Filter bowl capacity	105cc		
Lubricator bowl capacity	125cc		
Standard drain	Semi-auto drain (Drains below 0.5kgf/cm ²)		
Net weight	1380g (W/I Aluminum bowl 1680g)		
Option	Spacer block		

Dimensions

NUFR/L-02, 03, 04

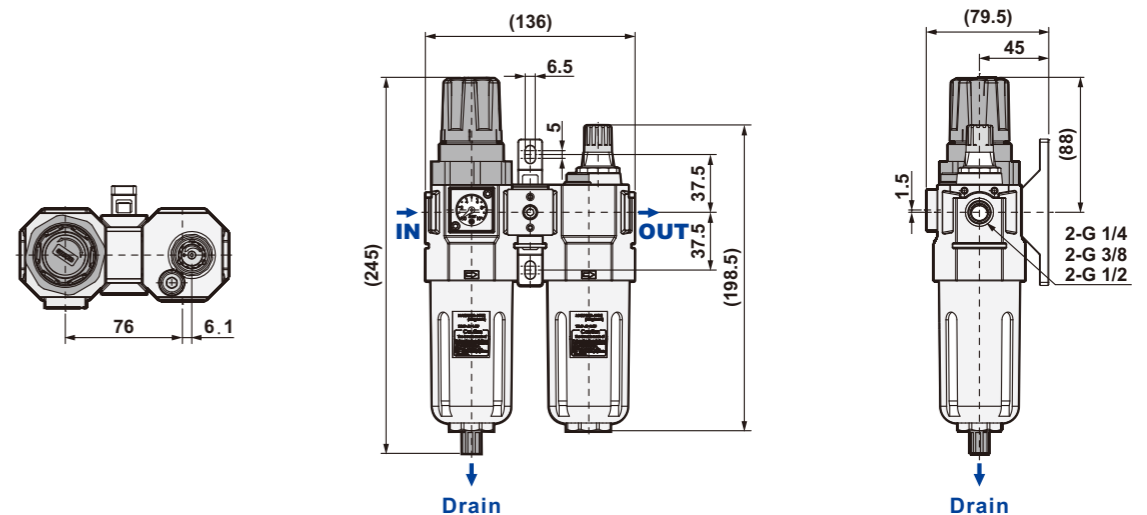

NUFR/L-02, 03, 04SB(Spacer block)

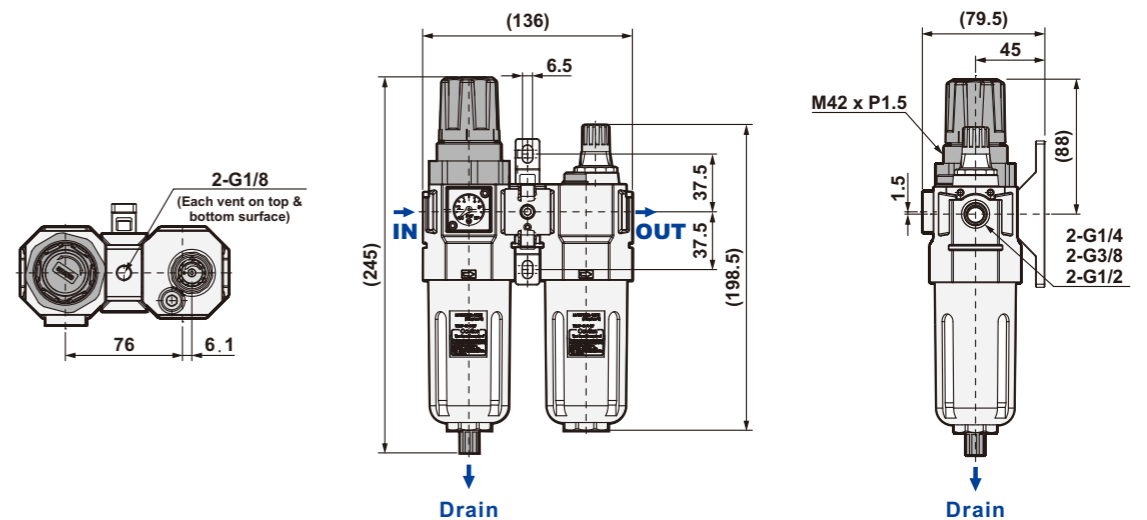

Flow chart

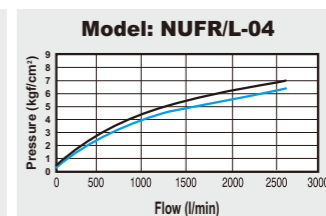
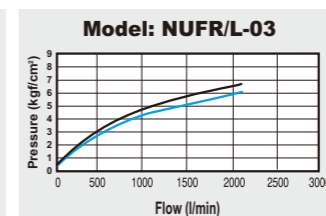
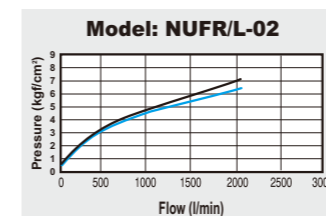

Note

X axis: Flow (l/min)
Y axis: Pressure (kgf/cm²)
Blue line (P0) = Outlet pressure
Black line (P1) = Inlet pressure
P1-P0= Pressure range

Construction(NUFR/L-02,03,04)

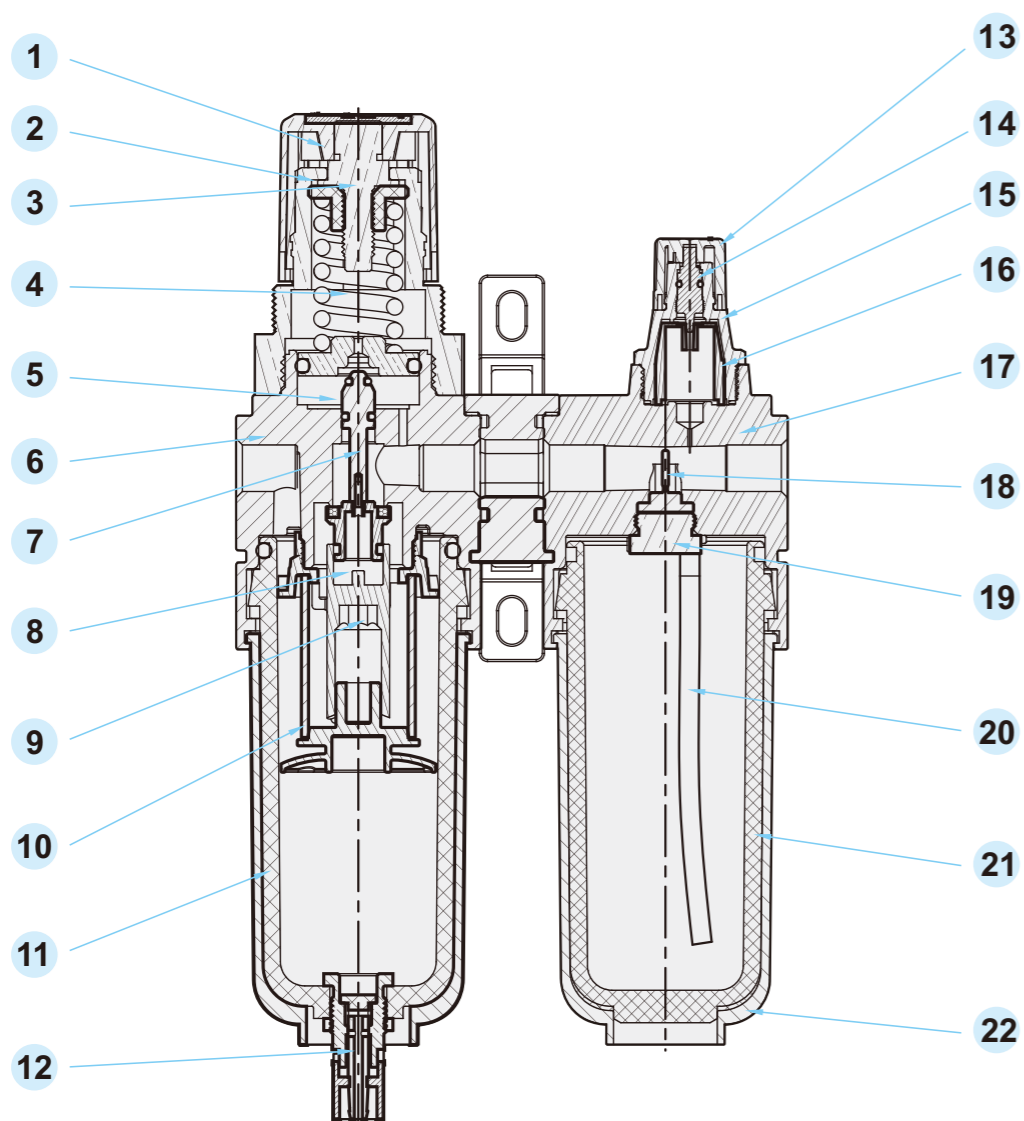

Memo...

No.	Description	Material	No.	Description	Material
1	Pressure regulating knob	NY	12	Semi-auto drain	POM
2	Regulator base	NY+GF	13	Oil adjusting knob	POM
3	Pressure regulating screw	Fe+Ni	14	Oil adjusting screw	Cu+Ni
4	Pressure regulating spring	Spring steel + Ni	15	Oil viewer	GV4H
5	Piston	Cu+Ni	16	Oil dropping orifice	PC
6	Regulator body	ADC12	17	Lubricator body	ADC12
7	Regulating needle	Cu+NBR	18	Damper	PU
8	Spring	SUS 304	19	Plug	Cu
9	Filter element holder	NY	20	Oil pipe	PU
10	Filter element	PE	21	Lubricator bowl	PC
11	Filter bowl	PC	22	Bowl guard	NY